

Suction Pressure Transducer

Model PR-265



- 100% solid state fused silicon pressure sensor
- Rugged, leak-proof 316L stainless steel monolithic pressure cavity with no welds, O-rings, or seams/bonds
- Up to 300% overpressure without zero shift
- Over 500% burst pressure
- Up to 3 field selectable ranges in a single unit
- Wide 12-40 VDC/12-35 VAC unregulated supply voltage
- Two temperature compensated output versions, 4-20 mA 2-wire or field selectable 0-5 VDC/0-10 VDC
- NIST traceable calibration
- Rugged NEMA 4 (IP-65) enclosure with external mounting bracket
- Short circuit and reverse polarity protected
- Conforms to EMC standards EN50082-1/EN55014/EN60730-1

The PR-265 incorporates sophisticated integrated circuits and a new fused silicon monolithic cavity pressure sensor to not only provide a high-level, fully-conditioned and temperature compensated output, but also to offer up to three (3) field selectable pressure ranges in one unit. The field selectable feature eliminates costly inefficiencies by providing a single unit which can be configured to cover all the pressure ranges for a particular application. For instance, 25.0, 50.0 and 100.0 psig in one unit. The 316L stainless steel monolithic pressure cavity not only provides media compatibility for most of the applications, but also offers a leak-proof solution for today's environment conscious customers. Two industry standard output versions are available, 4-20mA 2-wire loop or field selectable 0-5 VDC/0-10 VDC. Wide 12-40 VDC or 12-35 VAC unregulated supply voltage and a broad 0°F - 180°F compensated temperature range ensures compatibility to most of the applications. Rugged NEMA 4 (IP-65) enclosure, gasketed cover, external mounting bracket, fully temperature compensated NIST traceable accuracy and a liberal two year warranty are some of the features which make the PR-265 the industry's most reliable, rugged, and economical pressure transducer.



MAMAC SYSTEMS[®]
MONITOR • DECISION • CONTROL

7400 Flying Cloud Drive Minneapolis, MN 55344-3720 • USA
800/843-5116 • 612/835-1626 • FAX 612/829-5331
sales@mamacsys.com • www.mamacsys.com

Units 6&7 Baird House • Dudley Innovation Centre
Pensnett Estate • Kingswinford
West Midlands • DY6 8XZ • United Kingdom
TEL 01384-271113 • FAX 01384-271114

1st Floor • Esanda House • 104 Frome Street
Holden Hill • S.A. 5088 • Australia
TEL 08-232-4551 • FAX 08-232-4715

155 McIntosh Drive, Unit 5 • Markham
Ontario • L3R 0N6 • Canada
TEL 905-474-9215 • FAX 905-474-0876

5611 North Bridge Road
03-06 • Eng Cheong Tower
Singapore • 911901
TEL 65-3927273 • FAX 65-3927276

PR-265

The PR-265 sensing element is a 100% solid state silicon strain gauge fused directly onto the 316L stainless steel monolithic pressure cavity. The pressure cavity is machined out of a solid rod and does not incorporate any welds, seams, or bonds. In this way, the sensor not only offers excellent linearity, repeatability, and sensitivity, but also exhibits negligible hysteresis and withstands significant overpressure without zero shift. The monolithic nature of the cavity ensures not only leak proof operation but also enhances the overpressure and burst pressure specifications. The pressure cavity design incorporates novel techniques to isolate the fused silicon sensing element from installation related stress thereby ensuring zero integrity. The 316L stainless steel offers excellent media compatibility to most of the industrial and commercial applications.

The PR-265 incorporates sophisticated integrated circuits to not only provide a high level, fully conditioned and temperature compensated output, but also to offer field selectable flexibility which was unheard of in the industry. The PR-265 offers up to three field selectable pressure ranges in one unit. In this way, a customer does not need to know the exact pressure range prior to selection. A unit can be field configured for the desired pressure range in the field. With fixed range units, in case of engineering error or incorrect selection, the only solution is expensive field recalibration or time consuming product exchange or replacement. Similarly, numerous units have to be kept in stock as spares to cover all ranges in case of field failure. The PR-265 with the field selectable pressure range feature, eliminates above mentioned costly inefficiencies. A single unit can be configured to cover all the pressure ranges in a particular application thereby eliminating any possibility of incorrect range selection. Additionally, one unit can be kept in stock and, in the event of a failure, it can be field configured thereby eliminating the need to stock numerous fixed range units. (For a complete listing of all the ranges available, please see the ordering information section on page three.)

On VDC output units, two additional field selectable options are available: dual outputs 0-5 or 0-10 VDC, and dual unregulated supply voltages 12-35 VAC or 12-40 VDC. By merely moving a shorting plug, one can select the desired output for the specific application. As far as supply voltage is concerned, the unit automatically configures for AC or DC and no field selection is necessary. Another feature is that the output is fully protected from short circuit to ground, or if the supply voltage is applied by mistake to the output.

Past experience demonstrates that field related wiring problems do occur. Instead of denying this fact, the protection circuit is designed in to ensure trouble-free start-up. The VDC output unit is also designed to handle low impedance circuits. In fact, the unit can drive up to 1K ohms minimum. In this way, multiple controllers, indicators, or other devices can be paralleled to the output without performance degradation.

The mA output units can function over a wide unregulated supply voltage range: 12-40 VDC without any effect on calibration or performance. The unit has reverse polarity protection built in. As a result, it is next to impossible to damage the unit by mis-wiring. By using sophisticated low drop-out voltage regulators and CMOS integrated circuits, the mA output unit can drive very high output impedance. In fact, with only 12 VDC supply, the unit can drive 400 ohms. At 40 VDC, the unit is capable of handling up to 3000 ohms load. In this way, the output loop can be tied in series to multiple controllers, indicators, and other devices without degrading the performance.

Automated NIST traceable pressure controllers and precision pressure sensors are utilized to calibrate and certify the PR-265. Calibration data on each unit is archived digitally for SPC and QC purposes. All automated calibration systems are networked and data is available on-line to numerous individuals at the same time. In this way, extremely high standards of quality and calibration integrity are maintained. Each unit is individually temperature compensated in an environmental chamber. The temperature compensation data is also digitized and archived for future reference purposes. Compensating each unit individually ensures that published specifications are adhered to.

The PR-265 incorporates a rugged NEMA 4 (IP-65) fully gasketed, dust proof and splash proof enclosure. The enclosure has an external mounting bracket to facilitate field installation. A 1/2" (.875"/22.25mm dia.) knock-out for conduit connection is also provided. A liquid tight cable connector is also supplied if the unit is not being hard wired. Once installed, the enclosure maintains its environmental rating and protects the electronics and the sensing element from condensation, corrosive contaminants and other environmental pollutants. The unit also has additional features for ease of installation including unpluggable terminal block, easily accessible zero and span trimmers, and conveniently located shorting plugs for field selection.

PR-265

SPECIFICATIONS:

Accuracy*: $\pm 1\%$ FS

Overpressure: 300%

Burst Pressure: 500%

Supply Voltage: 12-40 VDC
12-35 VAC (VDC output units only)

Supply Current: VDC Units - 10 mA max.
mA Units - 20 mA max.

Enclosure: 18 Ga C. R. Steel NEMA 4 (IP-65)

Finish: Baked on enamel-PMS2GR88B

Conformance: EMC Standards EN50082-1(1992)
EN55014(1993)/EN60730-1(1992)

Compensated Temp Range: 0°F-180°F (-18°C-82°C)

T. C. Error: $\pm 0.025\%/^{\circ}\text{F}$ (.03%/°C)

Media Compatibility: Liquid/gases compatible to
316L stainless steel

Port Connection: 1/8" NPT

Environmental: 10-90% RH Non-Condensing

Termination: Unpluggable screw terminal block

Wire Size: 12 Ga max.

Load Impedance: 3K ohms max. at 40 VDC (mA
output units)
1K ohms min. (VDC output units)

Weight: 1.0 lbs. (.45 kg)

**Includes non-linearity, hysteresis and non-repeatability*

ORDERING INFORMATION: PR-265-

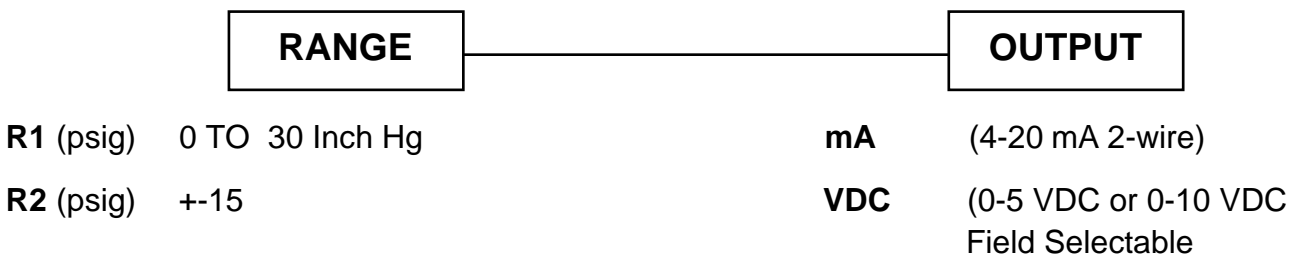

Example: PR-265-R1-mA: With R1 Range which has three(3) field selectable range options and 4-20 mA output.

CAUTION: Do not use on oxygen service, in explosive/hazardous environment or with flammable/combustible media.

PR-265

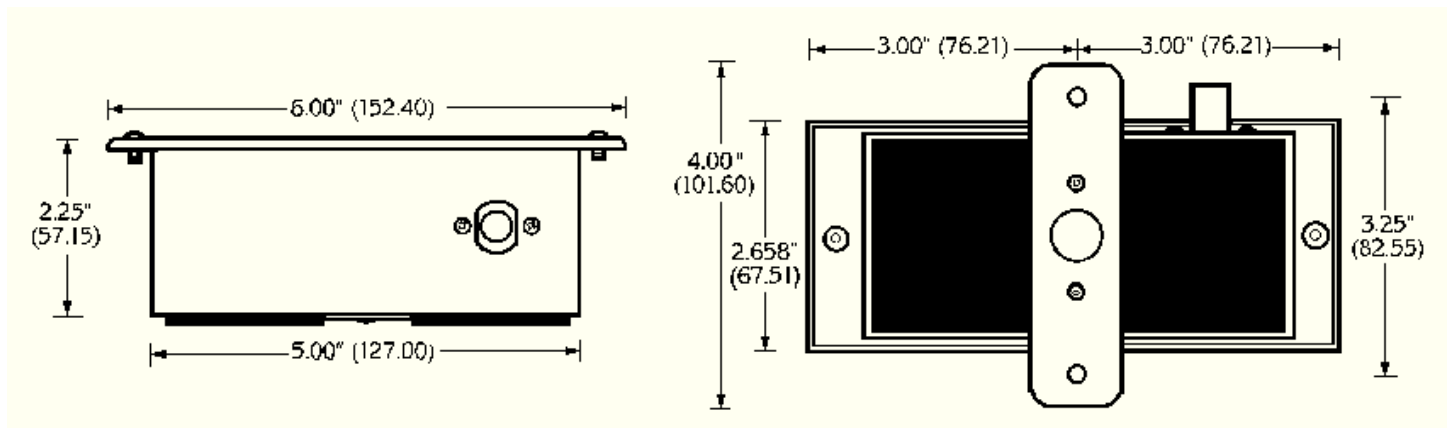

WARRANTY: MAMAC Systems, Inc. warrants its products to be free of defects in material and workmanship for a period of two (2) years from date of shipment. If a unit is malfunctioning, it must be returned to the factory for evaluation. A return authorization number (RMA) will be issued by the customer service department and this number must be written or prominently displayed on the shipping boxes and all related documents. The defective part should be shipped freight pre-paid to the factory. Upon examination by MAMAC Systems, Inc., if the unit is found to be defective, it will be repaired or replaced at no charge to the customer. However, this warranty is void if the unit shows evidence of being tampered with, damaged during installation, misapplied, misused, or used in any other operating condition outside of the unit's published specifications.

MAMAC Systems, Inc. makes no other warranties or representations of any kind whatsoever, expressed or implied, except that of title. All implied warranties including any warranty of merchantability and fitness for a particular purpose are hereby disclaimed. User is responsible to determine suitability for intended use.

LIMITATIONS OF LIABILITY: The remedies of buyer set forth herein are exclusive and the total liability of MAMAC Systems, Inc. with respect to this order, whether based on contract, warranty, negligence, indemnification, strict liability or otherwise, shall not exceed the purchase price of the product upon which liability is based. **In no event shall MAMAC Systems, Inc. be liable for consequential, incidental or special damages.** MAMAC Systems, Inc. reserves the right to change any specifications without notice to improve performance, reliability, or function of our products.

Every precaution for accuracy has been taken in the preparation of this manual, however, MAMAC Systems, Inc. neither assumes responsibility for any omissions or errors that may appear nor assumes liability for any damages that result from the use of the product in accordance with the information contained in the manual.



MAMAC SYSTEMS®
MONITOR • DECISION • CONTROL

7400 Flying Cloud Drive Minneapolis, MN 55344-3720 • USA
800/843-5116 • 612/835-1626 • FAX 612/829-5331
sales@mamacsys.com • www.mamacsys.com

Units 6&7 Baird House • Dudley Innovation Centre
Pensnett Estate • Kingswinford
West Midlands • DY6 8XZ • United Kingdom
TEL 01384-271113 • FAX 01384-271114

1st Floor • Esanda House • 104 Frome Street
Holden Hill • S.A. 5088 • Australia
TEL 08-232-4551 • FAX 08-232-4715

155 McIntosh Drive, Unit 5 • Markham
Ontario • L3R 0N6 • Canada
TEL 905-474-9215 • FAX 905-474-0876

5611 North Bridge Road
03-06 • Eng Cheong Tower
Singapore • 911901
TEL 65-39272573 • FAX 65-3927276